

## Simple RIII + Two 4x SuperMo Panasonic AK-UC4000 (200/240 fps mode) and Four HD cameras with Two replay workplaces

Replay configuration with two independent workplaces. First WP - Two Super Motion cameras in 4x mode, Second WP - 4 HD cameras (442). Each SuperMo camera - four HD SDI connections. DCT-based I-frame codec. SDI Output 1 (3) is used for Program1 (2). SDI Output 2 (4) is used for Preview 1 (2). Graphics Port 1 (2) - uses MultiSkin for displaying Main Interface (MI) or Multiviewer (MV). With Redundant Power Supply Option.

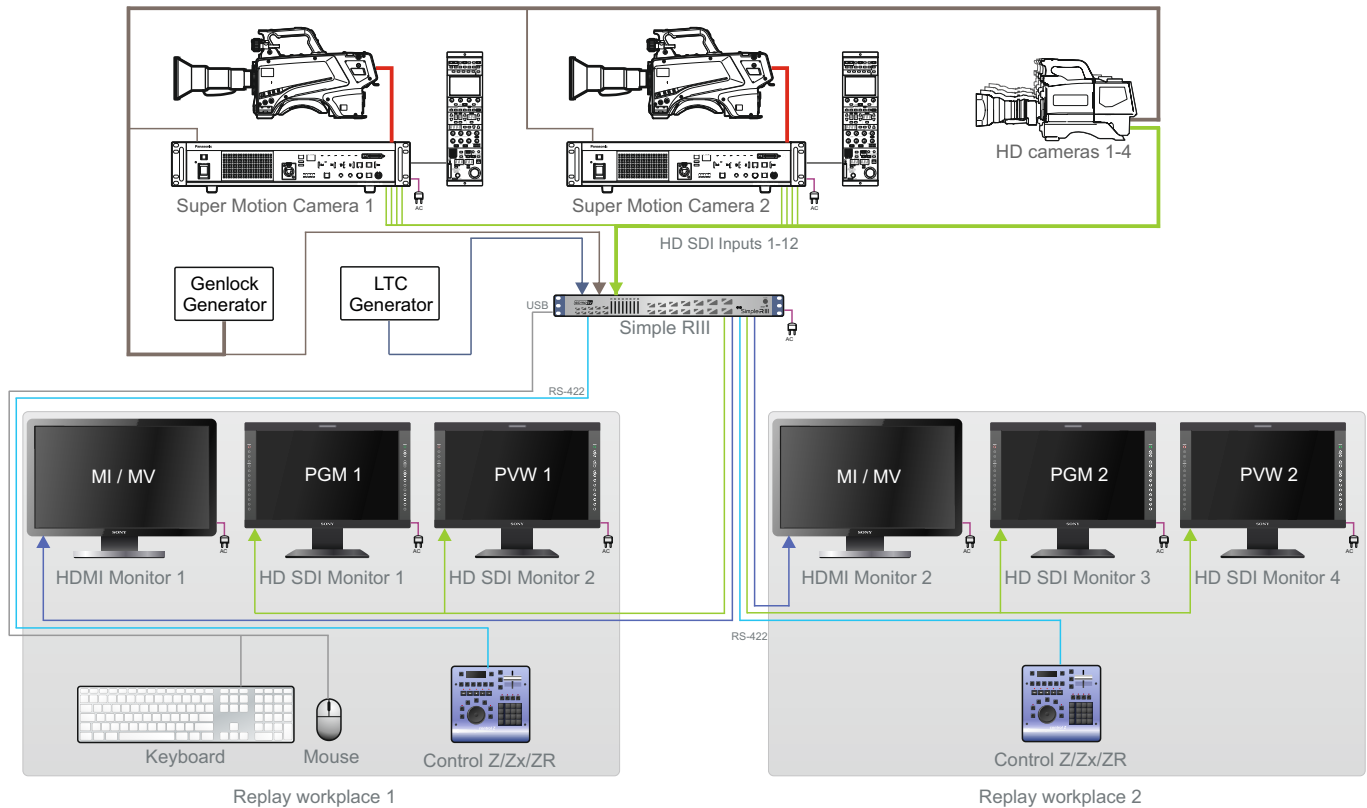

# Simple RIII + Two 4x SuperMo Panasonic AK-UC4000 (200/240 fps mode) and Four HD cameras with Two replay workplaces

Connection diagram

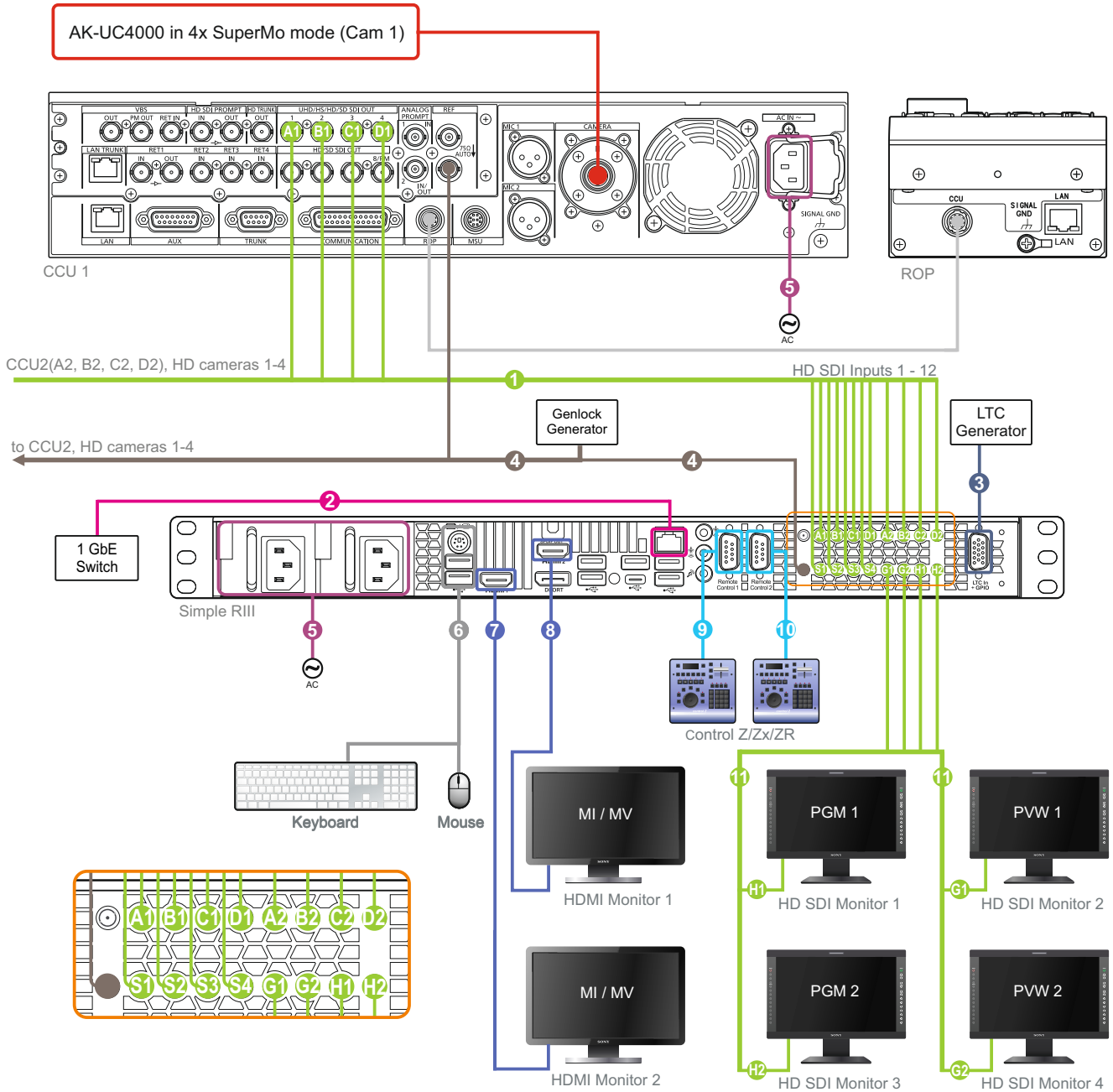

- 1 - HD SDI Inputs 1 - 12
  - A1, B1, C1, D1 - AK-UC4000 in 4x SuperMo mode (Cam 1)
  - A2, B2, C2, D2 - AK-UC4000 in 4x SuperMo mode (Cam 2)
  - S1 - HD camera 1
  - S2 - HD camera 2
  - S3 - HD camera 3
  - S4 - HD camera 4
- 2 - 1 GbE
- 3 - LTC Input
- 4 - Reference Input
- 5 - AC110/220 V 60/50Hz
- 6 - Keyboard and Mouse
- 7 - HDMI 1920 x 1080 Main Interface / Multiviewer Interface (Replay workplace 2)
- 8 - HDMI 1920 x 1080 Main Interface / Multiviewer Interface (Replay workplace 1)
- 9 - Control Z/Zx/ZR Remote Control (Replay workplace 1)
- 10 - Control Z/Zx/ZR Remote Control (Replay workplace 2)
- 11 - HD SDI Outputs
  - H1 - PGM 1
  - G1 - PVW 1
  - H2 - PGM 2
  - G2 - PVW 2

